

**SHARE**

Technology • Connections • Results

# Cheryl's Hot Flashes #25

Cheryl Watson

Watson & Walker, Inc.

[www.watsonwalker.com](http://www.watsonwalker.com) - home of Cheryl Watson's Tuning Letter,  
CPU Charts, BoxScore and GoalTender

March 4, 2011

Session 8797



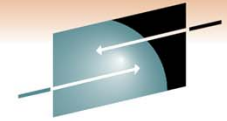

**SHARE**  
Technology • Connections • Results

# Agenda

- Introduction
- SMF Type 113s
- z/OSMF
- Mean Time to Wait
- zEnterprise Observations
- If I Ran The Site
- Neat APARs
- Neat Documentation
- At This SHARE



# Introduction

- Currently
  - Author of *Cheryl Watson's Tuning Letter* (40-60 pages six times a year) and *Cheryl Watson's CPU Charts*
  - Author of free email – *Cheryl's List* (sign up on website)
  - Developer of two Watson & Walker's software products, *BoxScore* and *GoalTender*
  - Long-time SHARE member/contributor (ribbon wearer since 1978)
  - CMG past director/contributor
  - CMG A. A. Michelson Award winner
  - zJournal Mainframe Hall of Fame
  - Presents “Hot Flashes” at every SHARE to talk about the things I'm passionate about

# Introduction

- History
  - 1965 – Math & physics major at Portland State; worked at Consolidated Freightways, wrote Autocoder on 1401 and 7010; installed MFT in 1966
  - 1967-1982 – Several software companies, Amdahl, and EDS (training, CICS admin, performance and capacity)
  - 1982-1986 – Morino Associates (England, Germany, Virginia)
  - 1986 – Met Tom Walker, partner and future husband, started Watson & Walker, Inc. as a training company (taught SMF, RMF, performance, WLM, capacity planning until 1999)
  - 1991 – Started *Cheryl Watson's Tuning Letter*
  - 1995 – Created WLM QuickStart Policy
  - **Never met an SMF record I didn't like!**

## SMF Type 113s

- CPU Measurement Facility (MF)
  - Hardware firmware to collect memory and CPU accesses on a z10 or z196
  - Measurements are done in firmware, so no overhead
- Hardware Instrumentation Services (HIS)
  - Software address space writes SMF and log records
    - Records counters (inexpensive) and samples (can use lots of CPU). Counters can be collected continuously.
    - Collect the SMF type 113 records – send them to John Burg (especially when moving from a z10 to a z196)
    - See SHARE sessions – [8882 \(John Burg\)](#), 8864/8862 ([Gary King](#)), 8790 ([Peter Enrico](#)), 8531/8532 ([Meral Temel](#))
    - <http://www.ibm.com/support/techdocs/atsmastr.nsf/WebIndex/TC000066> (link to John's most current presentation)

## SMF Type 113s

- Type 113s contain information to calculate the Relative Nest Intensity (RNI)
- Large Systems Performance Reference (LSPR) website publishes capacity estimates of each machine
  - Previously was type of workload (e.g. batch, online, WAS), but now by RNI and L1MP (level 1 cache miss per 100 instr)
  - So new workloads are high, low, or average RNI
  - What is your workload? You need 113s to know.
- What workloads do you run?
  - Run zPCR from ATS (Advanced Technical Skills)
  - Try our free tools - MXG programs at [www.watsonwalker.com](http://www.watsonwalker.com)
    - Note – MXG 29.02 is required

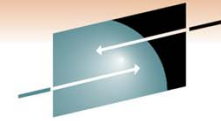

# Type 113 Analysis

START	CP/AP/IP	MIPS	L1MP	RNI	Hint
18FEB2011:00:00:00	7/1/3	327.7725	4.4428	1.3106	High
18FEB2011:01:00:00	7/1/3	660.5309	2.4861	0.9783	Average
18FEB2011:02:00:00	7/1/3	1001.4463	2.6266	0.9976	Average
18FEB2011:03:00:00	7/1/3	643.1000	2.7467	0.9861	Average
18FEB2011:04:00:00	7/1/3	457.1802	2.8425	1.0181	Average
18FEB2011:05:00:00	7/1/3	393.3294	3.2844	1.1992	High
18FEB2011:06:00:00	7/1/3	371.0539	3.3602	0.8732	Average
18FEB2011:07:00:00	7/1/3	329.4628	3.7300	1.1527	High
18FEB2011:08:00:00	7/1/3	444.1842	4.0464	1.1461	High
18FEB2011:09:00:00	7/1/3	346.3129	3.2562	1.2395	High
18FEB2011:10:00:00	7/1/3	377.0836	2.7425	1.1335	Average
18FEB2011:11:00:00	7/1/3	448.2267	1.7618	1.3872	Average
18FEB2011:12:00:00	7/1/3	335.5433	1.7104	1.2356	Average
18FEB2011:13:00:00	7/1/3	340.4203	2.1169	1.2221	Average
18FEB2011:14:00:00	7/1/3	288.3084	2.5571	1.2984	Average
18FEB2011:15:00:00	7/1/3	215.5665	2.6301	1.3301	Average
18FEB2011:16:00:00	7/1/3	285.5899	2.4152	1.1074	Average
18FEB2011:17:00:00	7/1/3	182.0070	2.5892	0.9726	Average
18FEB2011:18:00:00	7/1/3	109.6560	4.2820	1.1398	High
18FEB2011:19:00:00	7/1/3	228.9796	5.1788	0.8000	Average
18FEB2011:20:00:00	7/1/3	252.1256	4.8598	0.9119	Average
18FEB2011:21:00:00	7/1/3	264.8281	3.9618	1.3950	High
18FEB2011:22:00:00	7/1/3	273.1167	3.7105	1.6380	High
18FEB2011:23:00:00	7/1/3	330.8449	3.8115	1.4761	High

## z/OSMF

- Web-based admin tool for sysprogs
  - I've become a recent z/OSMF evangelist
    - Most important new facility since Workload Manager
    - IBM is firmly behind this (as evidenced by the amount of development and resources behind it) – this is NOT like eWLM, z/OS Software Manager, zMC
    - Fact – your company will need this
    - One attendee is expecting a mass exodus of MVS talent within 5 years; new sysprogs need this simplification
  - Rumor – too difficult to install and too many resources to run
    - This is constantly improving, but shouldn't stop you
    - The benefits are worth the investment



## z/OSMF

- Sessions on z/OSMF
  - 8922, [Anuja Deedwaniya](#) - *z/OSMF 1.12 Overview*
  - 8698, [Greg Daynes](#) – *z/OSMF 1.12 Implementation & Configuration*
  - 8859, [Stefan Wirag](#) – *Manage Your Workloads & Performance with z/OSMF*
  - 8696, [Karla Arndt](#) & [Anuja Deedwaniya](#) - *z/OS Problem Determination Update: z/OSMF Incident Log, Runtime Diagnostics, PFA, and New Technologies*

## z/OSMF

- Sessions on z/OSMF
  - 8757, [Mary Anne Matyaz](#) & [Brad Carson](#) - z/OSMF User Experience, see also 8512 (z/OS 1.12 User Experience)
  - 9075, [Anuja Deedwaniya](#) – z/OSMF Hands-On Lab
  - 9061, [Glenn Anderson](#) - *Understanding WebSphere App Server OEM for z/OSMF Sysprogs*
  - Redbook coming out soon

## z/OSMF

- The following slide is taken from session 8696 by [Anuja Deedwaniya](#)
  - This shows that several “best practices” should be in place before installing z/OSMF (e.g. CIM installed, CEA installed, OPERLOG operation, DAE, etc.)
  - In this slide, however, all pieces but the HMC and CIM pieces are just for use by the incident log function of z/OSMF
  - Although I think that the incident log function is the main reason to install z/OSMF, it can also be the hardest.
  - Recommendation: Just install the WLM Policy Editor in z/OSMF 1.12 to reduce setup time. Add Incident Log later.

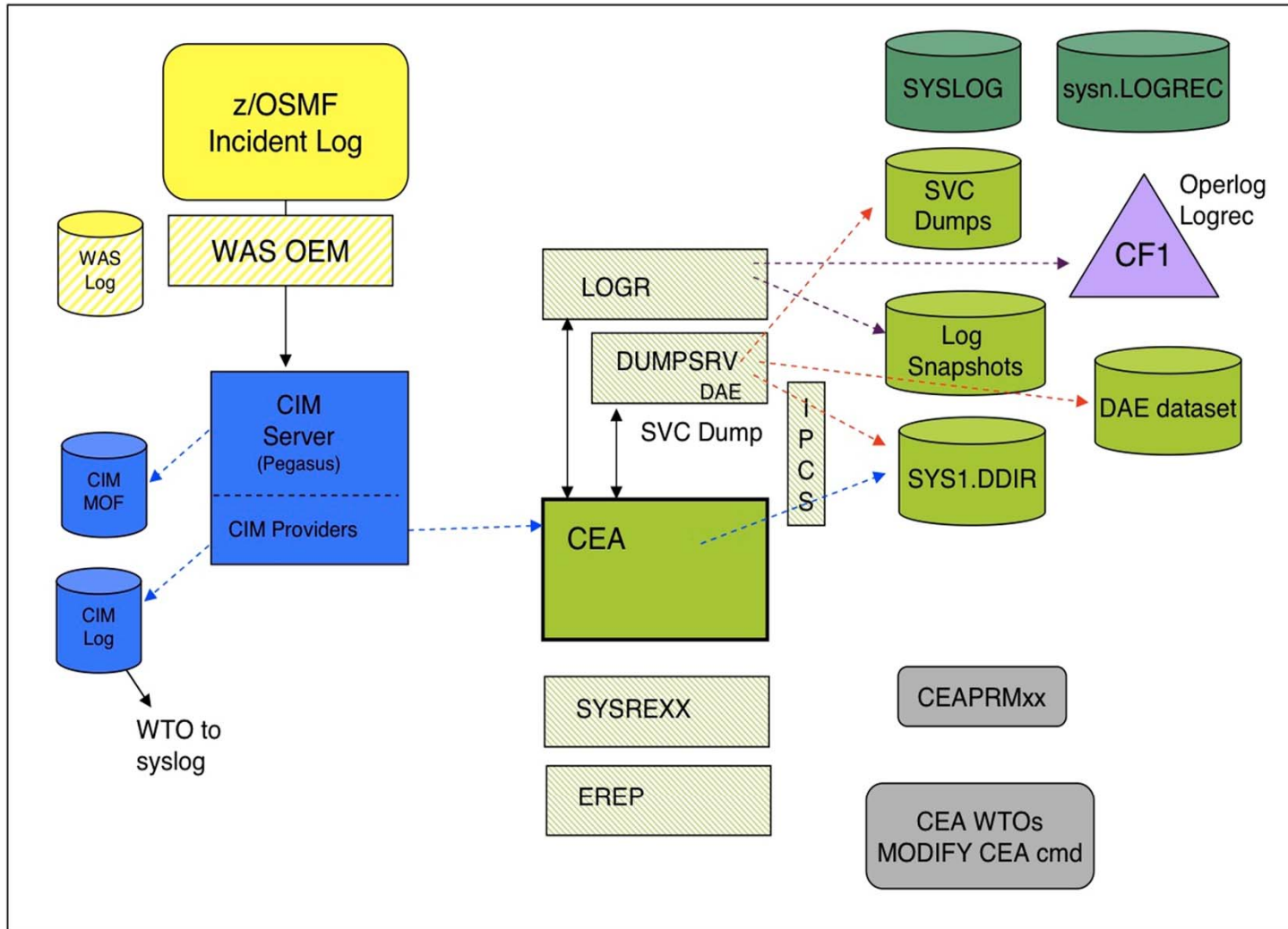

# Mean Time to Wait (MTTW)

- The best throughput is achieved when CPU-bound jobs are run at lower dispatch priority than I/O-bound jobs

**I/O-bound job:**

CCCwwwwwwCCCwwwwwwCCCwwwwwwCCC

**CPU-bound job:**

CCCCCCCCCwwwwwwCCCCCCCCCwwwwwwCCCCCCCCC

**Example 1:** I/O-bound job has the highest priority

CCCwwwwwwCCCwwwwwwCCCwwwwwwCCC

dddCCCCCdddCCCCwwwwwwCCCCdddCCCCwwwwwwCCCCCCCCC

The I/O-bound job is not delayed, but the CPU-bound job is delayed by 9 cycles.

**Example 2:** CPU-bound job has the highest priority

CCCCCCCCCwwwwwwCCCCCCCCCwwwwwwCCCCCCCCC

ddddddddddCCCwwwwwwdddddddCCCwwwwwwdddddddCCCwwwwwwCCC

The CPU-bound job is not delayed, but the I/O-bound job is delayed by 23 cycles.

Legend: C = CPU usage, w = I/O wait, d = delayed by higher priority work

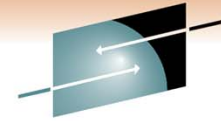

## Mean Time to Wait

- SRM uses MTTW for discretionary dispatch priorities
  - z/OS 1.12 – IEAOPTxx – CCCSIGUR=45

DP	MTTW (ms)	MTTW (microsec)
	155	2094-701
C9	0-5	0-7
C8	6-10	8-14
C7	11-15	15-21
C6	16-20	22-28
C5	20-25	29-35
C4	26-30	36-42
C3	31-35	43-49
C2	36-40	50-56
C1	41-45	57-63
C0	> 45	> 63

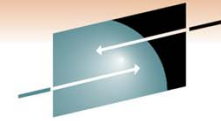

## Mean Time to Wait

- In z/OS 1.12, look at DPs, adjust CCCSIGUR as needed, increase IEAOPTxx TIMESLICES to reduce overhead for CPU-bound jobs
- For more information, see our z/OS 101 articles under 'Articles' at [www.watsonwalker.com](http://www.watsonwalker.com)

### RMF ASD Display:

```
15:03:44          S C R DP CS
JOBNAME  SRVCLASS P L LS PR  F
*MASTER* SYSTEM   1 NS   FF 2564
PCAUTH   SYSTEM   1 NS   FF  122
. . .
ANTAS000 STCLOM   1 NS   C1 1259
. . .
AXR      STCLOM   1 NS   C1  462
. . .
WWRYO    STCLOM   1 NS   C3  102
```

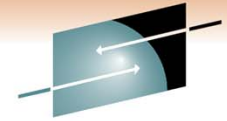

**SHARE**  
Technology • Connections • Results

## zEnterprise Issues

- zEnterprise Positioning
- Price of specialty engines (IFLs, zIIPs, zAAPs)
- Charging for work on zBX
- Power saving mode



## zEnterprise Positioning

- Next slide is often used by IBM to show the positioning of the zEnterprise with TCA and TCO considerations
- See sessions 8920 by [Harv Emery](#) and 9153 by [Jose Castano](#)
- I think this is one of the most helpful displays to show the difference between Linux on z/VM and zBX



# Service Levels to Match Your Business Needs

*Increased flexibility for your multi-architecture strategy when data is on z/OS*

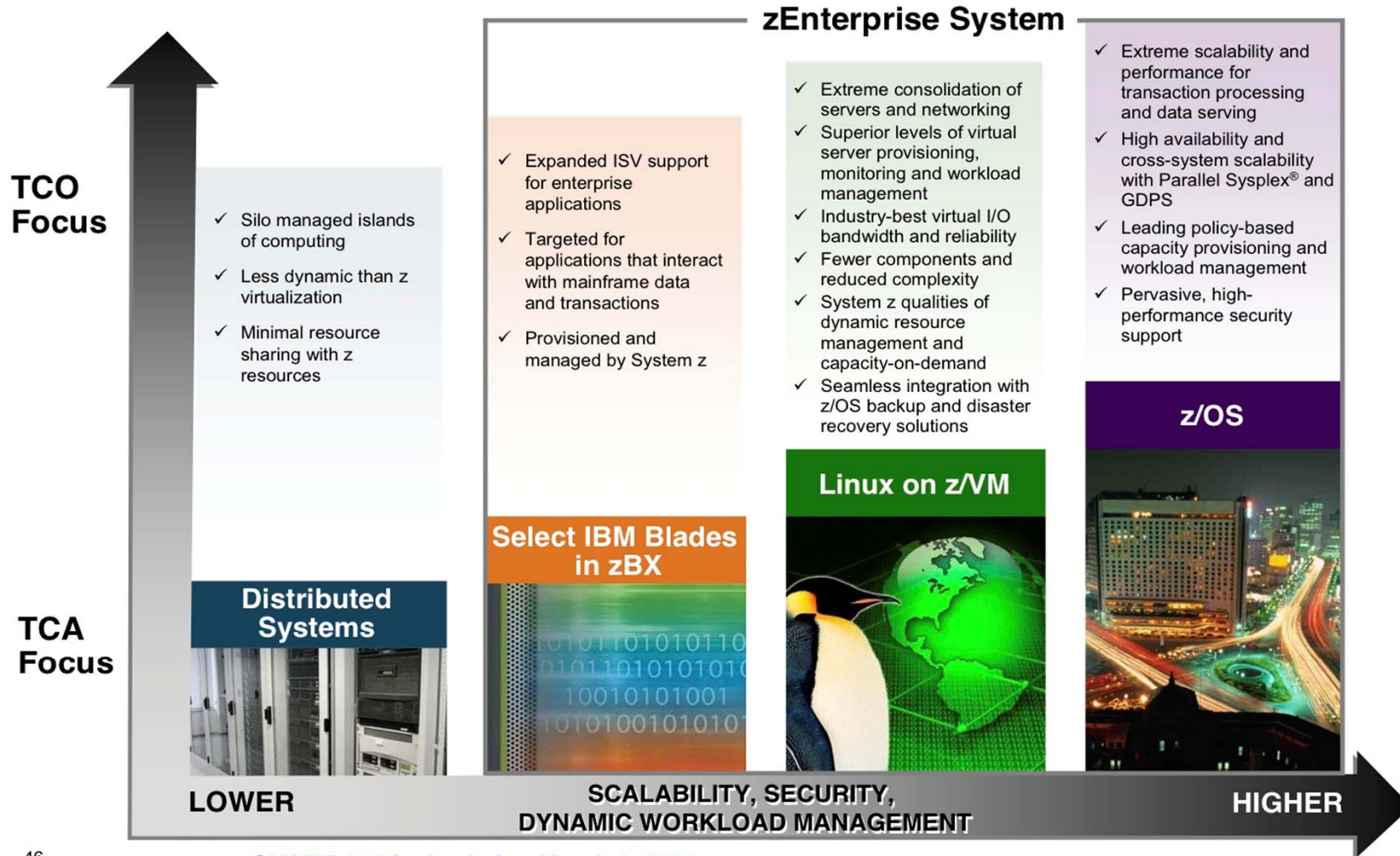

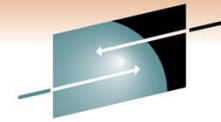

**SHARE**  
Technology • Connections • Results

## z196 Specialty Engines - IFL

Status	U.S. Price	Avg RNI MIPS (single IFL)	\$ per MIPS
New z9-BC	\$95,000	459	\$207
New z9-EC	\$125,000	560	\$223
New z10-BC	\$75,000	661	\$113
New z10-EC	\$75,000	901	\$83
<b>New z196</b>	<b>\$55,000</b>	<b>1204</b>	<b>\$46</b>
z9-EC to z10-EC Upgrade	\$0	+341	\$138
z9-EC to z196 Upgrade	\$33,000	+644	\$131
z10-EC to z196 Upgrade	\$16,500	+303	\$75

MIPS estimates come from *Cheryl Watson's CPU Charts, August 2010*

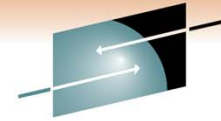

## z196 Specialty Engines – zIIP/zAAP

Status	U.S. Price	Avg RNI MIPS (single IFL)	\$ per MIPS
New z9-BC	\$95,000	459	\$207
New z9-EC	\$125,000	560	\$223
New z10-BC	\$125,000	661	\$189
New z10-EC	\$125,000	901	\$139
<b>New z196</b>	<b>\$100,000</b>	<b>1204</b>	<b>\$83</b>
z9-EC to z10-EC Upgrade	\$0	+341	\$139
z9-EC to z196 Upgrade	\$60,000	+644	\$153
z10-EC to z196 Upgrade	\$30,000	+303	\$128

MIPS estimates come from *Cheryl Watson's CPU Charts, August 2010*

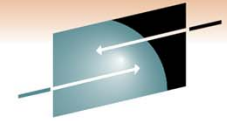

**SHARE**  
Technology • Connections • Results

## z/OS zBX Issues



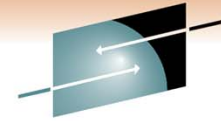

**SHARE**  
Technology • Connections • Results

## z/OS zBX Issues

- When you do capacity planning and chargeback for DB2, Java, etc., how do you deal with CPU time accumulated on a zIIP or zAAP?
  - Example: A CICS transaction issues a request to DB2, which runs part of the query on a zIIP.
    - Some days it runs on the zIIP, some days it doesn't.
    - When it all runs only on the z10, it accumulates CPU time at speed of z10.
    - When part of it runs on the zIIP, it accumulates CPU at speed of zIIP (can be several times faster than z10).
    - The SMF records contain a normalization factor so you can charge the zIIP time at native speed or normalized speed. It's your option.

## z/OS zBX Issues

- Now add a zBX
  - Using same example, assume that DB2 and IBM Smart Analytics Optimizer decide to send the query to a blade server.
  - The zBX does not have MIPS assigned, so there is no normalization factor.
  - One day it could cost a user \$10 for a request if it used the zBX, but the next day it might cost \$500.
  - **Elapsed time on zBX will be in SMF DB2 records.**
  - How will you charge? How will you plan the capacity?

## z196 Power Saving Mode

- Excellent new facility on z196 to reduce power consumption when not needed.
- BUT, CPU time measurements could be inaccurate.
- The service unit factor is changed, so all CPU times that are accumulated in service units are fine, but CPU times accumulated in seconds (milli-, micro-) are not modified.
- So a job that takes 10 seconds of CPU time during normal processing could take 12 seconds of CPU time during power saving mode.
- **Caution: Give chargeback and capacity planning departments plenty of notice before utilizing this feature!!**



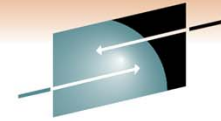

**SHARE**  
Technology • Connections • Results

## If I Ran the site . . .

- While attending SHARE in Boston, I kept seeing suggestion after suggestion to improve the data center. Many of these are the same recommendations that have been given for years.
- Why aren't people doing them?
  - Not enough staff.
  - It takes so much time to install a release, roll it out, and maintain it, that there's no time left to exploit it.
  - Managers don't want any changes that could impact production.
  - Too many inexperienced people.
  - Internal politics.
  - Green screen is faster.

## If *I Ran* the site . . .

- I'd start with baby steps, such as:
  - Schedule an hour a week, an hour a day, one day a month to work on enhancements.
- If not on z/OS 1.11, then start planning for z/OS 1.12. I would rather be on 1.12 than on 1.11 because of added performance benefits and features.
- See my SHARE “Hot Flashes” session in Boston for my suggestions

## Neat APARs

- [OA31731](#) (z/OS 1.0-1.12, 29Dec2010) – *New Function – BCPii Samples.*
- [OA34374](#) (z/OS 1.10-1.12, 22Dec2010) – *New Function. Adds SMARTEPOVER to IFASMF DL (SMF Logger dump program).*
- [OA35411](#) (DOC, 2Feb2011) – *Considerations for Use of EAV Volumes for HSM Owned DASD.*
- [PM19034](#) (DB2 9-10, 5Jan2011) – *New Function – Allow Check with SHRLEVEL Change to use FASTREPLICATION(REQUIRED) When Invoking DSSCOPY. See Willie Favero's blog at [it.toolbox.com](http://it.toolbox.com).*

## Neat APARs

- [PM27872](#) (DB2 10, 4Feb2011) – *SMF Decompression*. Can use after setting SMFCOMP to ON. This program shows you the effectiveness of the compression.
- Not an APAR, not neat, but very recent (this week):
  - A site installed Driver '79' maintenance to several plexes
  - z196 LPARs were fine, but z10s no longer showed any central storage (SMF70CSF=0)
  - PMR response: "Please open a hardware record indicating SMF70CSF is zero and you will need hardware MCL N24404.008 in Bundle 37."

## Neat Documentation

- WSC [PRS4467](#) – *Advanced Technical Skills – YouTube Video Flyer with Hiperlinks*. Twelve videos on WOLA (WebSphere Optimized Local Adapters) and IBM Modern Batch (with WebSphere).
- WSC [WP101788](#) – *Beginners Guide to Coding Java Batch Jobs*.
- Redpaper – [REDP-4590-01](#) (22Dec2010) – *Exploiting the IBM Health Checker for z/OS Infrastructure*.
- Redbook [SG24-7778-01](#) (17Dec2010) – *IBM CICS Explorer*.

## Neat Documentation

- Redbook [SG24-7817-00](#) (11Jan2011) – *System z Parallel Sysplex Best Practices*.
- Redbook [SG24-7919-00](#) (4Feb2011) – *SMF Logstream Mode: Optimizing the New Paradigm*. Additional materials also contains a sample IEF SMFDL program.
- Note: If you want to continue to see these wonderful Redbooks from the ITSO center, please take the time to rate them on the Redbook site ([www.redbooks.ibm.com](http://www.redbooks.ibm.com))

## At This SHARE

- z/OS Performance Improvements
- Each new release . . .
  - Takes fewer CPU resources
  - Provides great gobs of new features
  - The following slide shows one reason you would want to keep very current with your upgrades. Slide comes from excellent session, 8861, by [Marianne Hammer](#), IBM – z/OS *Performance Issues*.

## z/OS Release-to-Release Performance Improvements

- Focus on performance improvements:
  - Future z/OS releases
  - z/OS SW stack

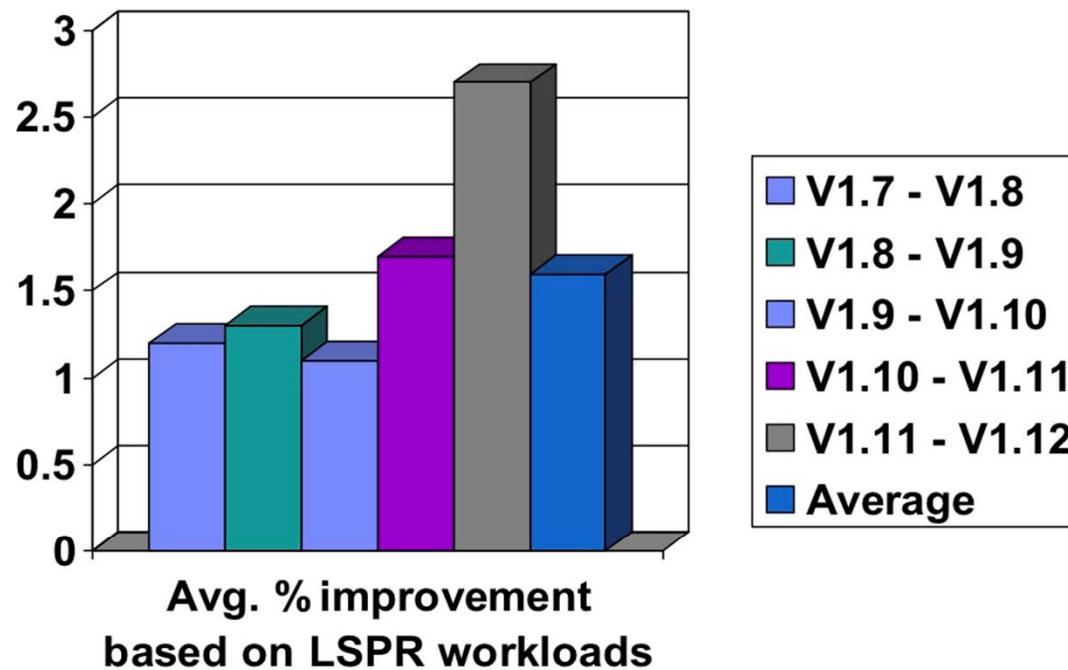



## At This SHARE

- [Frank Kyne](#), IBM ITSO
  - SHARE session 9038 - *z/OS Planned Outage Avoidance*
  - Redbook [SG24-7328](#) describes facilities up to z/OS 1.7; this session expands on that by listing facilities after 1.7
  - Neat stuff:
    - SYMUPDTE can change or add system symbols after IPL. Now found in SAMPLIB(IEASYMUP), but documented in the Redbook
    - [SA22-7505-xx](#) – z/OS Summary of Message and Interface Changes – lists changes, deletions, or additions of samplib, parmlib, and proclib members, in addition to changes in messages
    - Redbook has documentation on data set called SYS1.MSGENU that can be used to identify message changes

## At This SHARE

- 9027, [Glenn Anderson](#) - *A Mainframe Guy Discovers Blades – as in zEnterprise “Blade” Extension*
- 9066, [Glenn Anderson](#) - *A Mainframe Guy is Still Thinking About Cloud Computing*
- 8697 – z/OS Requirements: Influencing IBM Development

## At This SHARE

- 9022, [John Eells](#) - *zNextGen's A SHARE'd History of the Mainframe: The Chronicles, Artifacts and Stories*
- 9028, [Mark Brooks & Nicole Fagen](#) - *Parallel Sysplex Resiliency*
  - Neat tidbit from Nicole – her favorite new IPCS command in z/OS 1.12 is 'ip systrace perfddata'. Use it for currently running system to see all address spaces and CPU usage, plus lots more.
- 8763/8764, [Ray Wicks](#) - *Getting Starting in (z/OS) Capacity Planning (Parts 1 & 2)*

## Best Reasons to Return to SHARE

- zEnterprise
- zBX
- z196
- z/OS 1.12
- zManager (i.e. Unified Resource Manager)
- BladeCenter
- Blades
- Hypervisors
- Firmware
- Ensembles . . . My brain is full!

# See You in Orlando!

Cheryl Watson Walker with partner,  
husband, and best friend Tom Walker  
in Athens in June

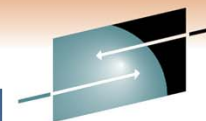
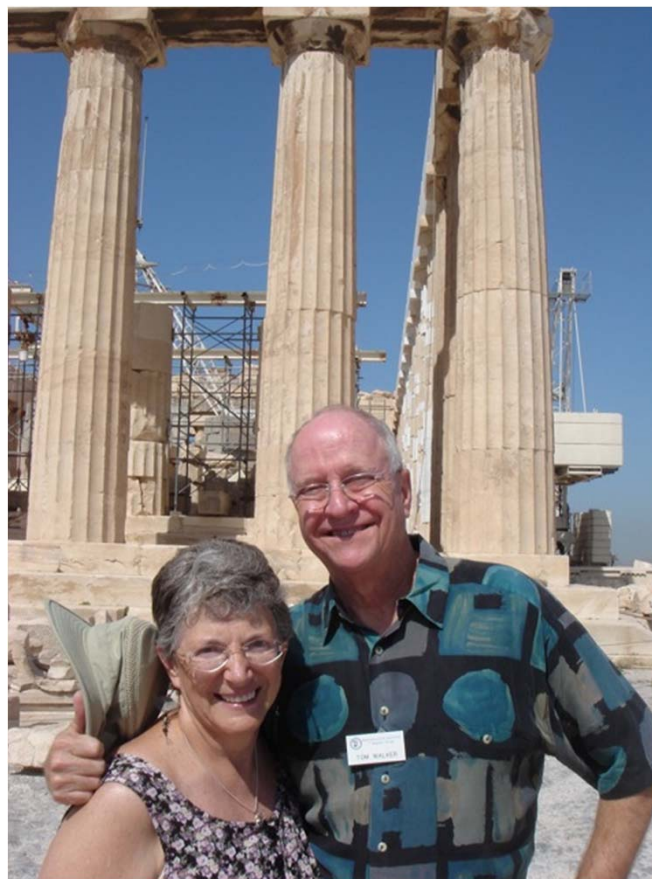

**SHARE**

Technology • Connections • Results

- Email: [technical@watsonwalker.com](mailto:technical@watsonwalker.com)
- Website: [www.watsonwalker.com](http://www.watsonwalker.com)